

Evaluating 1588v2 Performance

Rev 2

How to evaluate the performance of both 1588v2 Boundary clocks (BCs) and 1588v2 Transparent clocks (TCs) based on solutions from Calnex and Xena Networks.

APPLICATION NOTE

IEEE 1588v2 is the preferred protocol for transport frequency and phase synchronization over Ethernet, which is required for 3G and 4G mobile networks.

Ethernet devices & traffic add Packet Delay Variation (PDV), which can affect 1588v2 clock recovery. If you only rely on an Ordinary (Slave) Clock, PDV can mean the recovered frequency and phase do not meet accuracy specs. Adding Boundary clocks (BCs) and Transparent clocks (TCs) to the network helps Slave clocks recover frequency and phase more accurately. BCs effectively reduce the PDV, while TCs report the delays to the Slave Clock.

This Application Note describes a test plan for evaluating the performance of both Boundary clocks (BCs) and Transparent clocks (TCs) based on solutions from Calnex and Xena Networks.

INTRODUCTION TO 1588V2 PERFORMANCE TESTING

Ethernet was not designed for time-sensitive applications. However, its ubiquitous deployment has made it the preferred low-cost networking technology, and this has driven the development of standards like IEEE-1588 PTP that make it suitable for use in situations requiring very precise timing.

Critical elements for ensuring the accurate time and phase delivery over Ethernet using IEEE-1588 PTP are Transparent Clocks (TCs) and Boundary Clocks (BCs).

However, the performance of TCs and BCs is fundamentally affected by variations in traffic loading. To test the performance of TCs and BCs, both a 1588 PTP Sync analyzer for PDV and Performance analysis, and a traffic generator such as Xena Networks' ValkyrieCompact or ValkyrieBay to load and change the load on the TCs and BCs) should be used.

THIS DOCUMENT COVERS

1. An outline of a test plan for evaluating the performance of 1588v2 Boundary Clock (BC) devices and Transparent Clock (TC) devices.
2. Guidance on the set of tests that compare the network performance with and without 1588v2-aware devices.
3. A quantitative assessment of the performance of devices post-deployment.

THE FOLLOWING IS THE GENERIC TEST CONFIGURATION:

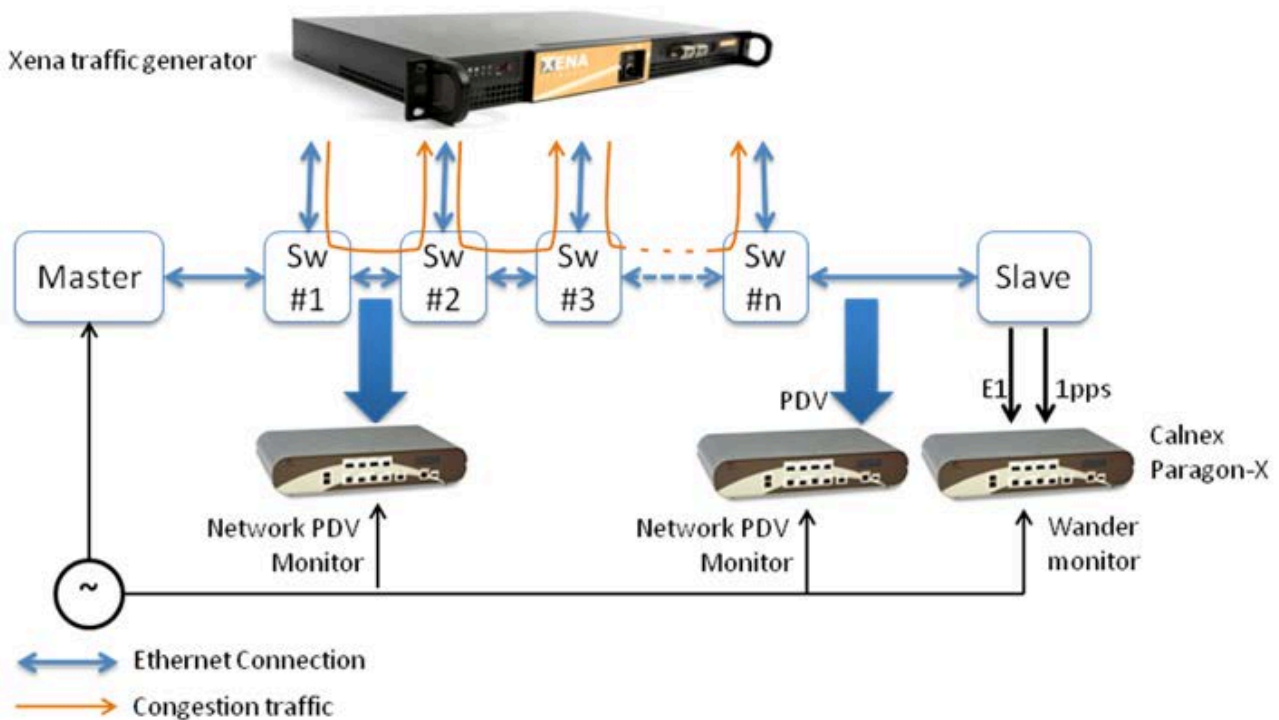

Figure 1 Generic test configuration

NOTES ON TEST CONFIGURATION:

- The congestion traffic can be based on the G.8261 Appendix VI Test Case 13 profile as this is widely used across the industry as a benchmark. i.e.
 - a) Forward direction: 1 hour of 80% ⇒ 1 hour of 20%, repeated.
 - b) Reverse direction: 1 hour of 50% ⇒ 1 hour of 10%, repeated.
 - c) Network Traffic Model 2.
- Test Case 14 is also popular but as this is a 24 hour test, it may be deemed to extend the total testing time too much, especially if multiple passes are performed. However, if it is also used, this would be a useful second data point.
- Testing using Live traffic instead of a Traffic Generator is also of value if this is possible.

NB: It is vital that the Traffic Generator be configured to avoid no beating effects caused by packet generation patterns being identical / very similar on each output. This occurs when large traffic packets are transmitted from multiple ports at the same time and hit every switch simultaneously, causing the PDV to be much higher than intended by the standards. Calnex dithers the TX time of the packets a little to prevent this.

Calnex uses a Gigabit Ethernet traffic generator from **Xena Networks** and can supply guidance on configuring this device if this is being used.

- In all the testing, record:
 - a) Network PDV i.e. the PDV at the input to the slave device.
 - b) Frequency wander on the E1/T1 output from the slave.
 - c) Phase wander on the 1pps output from the slave.
- It is also worth recording the Network PDV at the output of the first Switch, especially when it is configured as a BC or TC. This will provide an interesting data point for the performance of each individual device.
 - a) It is not necessary to do this with every run hence the PDV monitor device used to normally monitor the Network PDV at the input to the Slave can be moved for this specific case.
- When the congestion traffic is started, it is important to allow sufficient settling time before the wander testing is started. This should be at least 15 minutes (as suggested in G.8261), but may be significantly longer.
 - a) It is possible in the Paragon Wander Analysis tool to select a sub-set of the captured wander data to have the MTIE/TDEV analysis performed on. It is therefore not a problem if the wander capture is stated too early.
- It is also useful to perform the network test using 2 different numbers of switches. For example, using 5 and then 10 switches. This helps to clarify impact of wander accumulation.
 - a) Building a network with 10 switches represents a lot of equipment so it may not always be practical to achieve this. Doing testing with 3 & 5 or 3 & 6 switches should still provide useful data.
- It is suggested that each test is run for at least 6 hours to provide a clear indication of the wander accumulation process.

- a) It may also be worthwhile running a test for say 12 hours to check the performance is adequately demonstrated during the selected runtime (e.g. 6 hours). Again, if the first test is run for the extended period, is it possible to use the Paragon Wander Analysis tool to select a subset of the data (e.g. the first 6 hours) to check the MTIE & TDEV results are the same irrespective if, for example, a 6 hour runtime or 12 hour runtime is used.

SELECTING A TEST PLAN

The configurations selected depend on the configurations available. The complete set that could be utilized in switches with:

- a) No 1588v2 on-path support and no SyncE capability.
- b) No 1588v2 on-path support and SyncE capability.
- c) BC configured switches and no SyncE capability.
- d) BC configured switches and SyncE capability.
- e) TC configured switches and no SyncE capability.
- f) TC configured switches and SyncE capability.

It is suggested that the first test run is with configuration a) i.e. no on-path support or SyncE, as this will provide a baseline perform to demonstrate the improvement achieve when using BC, TC &/or SyncE capability.

It is also suggested that if configuration c) &/or d) is used, an addition test is performed with no Congestion Traffic (i.e. the Traffic Generator does not produce any packets). This will provide a baseline indication of the inherent noise produced by the multiple 'clock recovery & regeneration' functions within the BCs.

As an example, the following is a suggested set of tests for the case where 8 switches are available that can be configured with SyncE support for frequency transfer plus the ability to enable 1588v2 BC capability for either frequency & phase transfer or just phase when SyncE is being used of frequency;

1. **8 switches, No 1588v2 On-path Support, No SyncE**
⇒ PTP for Frequency & PTP for Phase without on-path support.
2. **8 switches, No 1588v2 On-path Support, SyncE enabled**
⇒ SyncE for Frequency & PTP for Phase without on-path support.
3. **5 switches, all in 1588v2 BC mode, No SyncE**
⇒ PTP for Frequency & PTP for Phase with BC on-path support.
4. **8 switches, all in 1588v2 BC mode, No SyncE**
⇒ PTP for Frequency & PTP for Phase with BC on-path support.
5. **8 switches, all in 1588v2 BC mode, No SyncE**
⇒ PTP for Frequency & PTP for Phase with BC on-path support.
No Congestion Traffic.
6. **5 switches, all in 1588v2 BC mode, SyncE enabled**
⇒ SyncE for Frequency & PTP for Phase with BC on-path support.

7. 8 switches, all in 1588v2 BC mode, SyncE enabled

⇒ SyncE for Frequency & PTP for Phase with BC on-path support.

8. 8 switches, all in 1588v2 BC mode, SyncE enabled

⇒ SyncE for Frequency & PTP for Phase with BC on-path support.
No Congestion Traffic.

Useful results can be produced without having to perform all the tests listed. The more the better but there is a clearly practical issues due to the time to perform these which needs to be taken into consideration when generation your test plan.

ANALYSIS OF RESULTS

The results from the testing can be compared by analysis of the 3 monitor points i.e. the PDV before the Slave, the Frequency stability from the T1/E1 output and finally the phase error from the 1pps output.

• Packet PDV Analysis

- a) Record the graph of PDV across the full measurement period.
- b) Record the maximum PDV across the full measurement period.
- c) When TCs are used, the PDV should calculated using the CorrectionField values as this is the PDV that will be observed by the Slave device.
- d) Compare graphs between the various test cases to understand the impact of using SyncE, BCs &/or TCs.

• E1/T1 Frequency Analysis

- a) Generate the MTIE result and compare to the appropriate ITU-T mask. The performance will be specified in the DUT Performance Specification document. It is likely to be a mask from G.812, G.813, G.823 &/or G.824.
- b) Generate the TDEV result and compare to the appropriate ITU-T mask.
- c) Record the graph of MTIE & TDEV with the relevant mask shown on the graph.
- d) Compare graphs between the various test cases to understand the impact of using SyncE, BCs &/or TCs.

• 1pps Phase Analysis

- a) Record the graph of 1pps wander across the full measurement period.
- b) Record the maximum phase offset ($X\mu\text{sec}$) across the full measurement period.
 - i. If measurement is performed against a 1pps reference, record the $+X\mu\text{sec}$ & $-Y\mu\text{sec}$ deviation observed.
 - ii. If no 1pps is available and a stability measurement is being performed, record the pk-to-pk $X\mu\text{sec}$ variation.
- c) Compare results to the equipment specification.
 - i. The performance will be specified in the DUT Performance Specification document. It is likely to of the form $\pm X\mu\text{sec}$.
- d) Compare graphs between the various test cases to understand the impact of using SyncE, BCs &/or TCs.

- Potential Observations when BCs are in use:

- a) Look for low frequency content in the PDV pattern as this has the potential to cause wander in the Slave.
- b) Compare the PDV for the case with no congestion traffic and with congestion traffic. This will indicate the impact of congestion traffic on the system.
 - i. A small difference is optimum as it indicates the BC is not unduly impacted by congestion traffic.
- a) Compare the E1/T1 MTIE/TDEV graphs for the various cases to determine the impact of using SyncE &/or BCs.
- b) Compare the E1/T1 MTIE/TDEV graphs for the various cases with all the switches (e.g. 8 switches) to the case with reduced number of switches (e.g. 5 switches) to observe the accumulation effect of using different numbers of switches.
- c) Compare the 1pps Phase variation for the various cases to determine the impact of using SyncE &/or BCs.
- d) Compare the cases with and without SyncE to determine the impact of using SyncE as well as BCs.

- Potential Observations when TCs are in use:

- a) Observe if the magnitude of the PDV (when the CorrectionField is used in the calculation) varies dependent on the congestion traffic loading. If this is the case, then there is the potential for low frequency content in the PDV pattern which has the potential to cause wander in the Slave.
 - i. A small difference is optimum as it indicates the TC is not unduly impacted by congestion traffic.
- b) Compare the E1/T1 MTIE/TDEV graphs for the various cases to determine the impact of using SyncE &/or TCs.
- c) Compare the E1/T1 MTIE/TDEV graphs for the various cases with all the switches (e.g. 8 switches) to the case with reduced number of switches (e.g. 5 switches) to observe the accumulation effect of using different numbers of switches.
- d) Compare the 1pps Phase variation for the various cases to determine the impact of using SyncE &/or TCs.
- e) Compare the cases with and without SyncE to determine the impact of using SyncE as well as TCs.

GLOSSARY

BC	Boundary Clock
CDMA	Code division multiple access
DUT	Device under test
EEC	Ethernet Equipment Clocks
ESMC	Ethernet Synchronization Messaging Channel
FDD	Frequency Division Duplex
FDV	Frame Delay Variation
GM	Grandmaster clock
GPS	Global Positioning System
GSM	Global System for Mobile Communications
LTE	Long Term Evolution
MBMS	Multimedia Broadcast Multicast Service
MIMO	Multiple-input/multiple-output
MTIE	Maximum Time Interval Error
PDH	Plesiochronous Digital Hierarchy
PDV	Packet Delay Variation
Ppb	Parts per billion
Ppm	Parts per million
PRC	Primary reference clock
PSN	Packet-switched network
PTP	Point to point
QL	Quality level
SSM	Synchronization status messages
TC	Transparent Clock
TDD	Time Division Duplex
TDEV	Time deviation
TDM	Time Division Multiplexing
ToD	Time of Day
ToS	Top of Second
UMTS	Universal Mobile Telecommunications Systems